



# INFINITY PIPE SYSTEMS

## Compressed Air Solutions

The non-corrosive extruded aluminium pipe provides structural strength in a leak free piping system. Infinity aluminium pipe has a much thinner wall than that of plastic pipe, however it is naturally stronger and provides more air flow. Due to its larger internal diameter, Infinity aluminium pipe allows for, on average, a 23% higher flow rate than poly piping. Galvanised steel, copper and plastic piping systems have been the standard products used in the industry for years; however, these systems may be costing you a lot more than you realise.

Unlike Infinity Pipe Systems, copper piping systems are not designed to reduce condensation. As well as their inefficient design, copper systems require more time to install and additional work to comply with identification standards.

Galvanised pipe corrodes on the inside where it can't be seen, causing reduced flow and increased pressure drop. High pressure drop makes your system highly inefficient, as it struggles to provide the required air flow to the end user. Furthermore, when plastic is not correctly installed it will sag and bow, resulting in potential condensate collection points.

Infinity aluminium pipe offers one of the first all metal piping systems, specifically designed with energy savings in mind. Infinity pipe and fittings keep the fluid flow laminar; therefore reducing turbulence, minimising pressure drop and removing condensation.

The high quality standard set by the Infinity piping system also means that it is ideal for air, vacuum, nitrogen & other inert gases and is available in a selection of colours to meet required regulations.

# Infinity Pipe Systems



## INFINITE TIME SAVING

- ✓ Simple push in system
- ✓ Modular connection
- ✓ Light-weight tubing
- ✓ Fully adjustable and reusable, ideal for future expansion
- ✓ Easy identification - colour coded piping
- ✓ Less clips; minimal expansion
- ✓ No need for swan necks - built-in **zero condensate** tees for low pressure systems
- ✓ Adapts to all existing pipe systems



## INFINITE QUALITY

- ✓ Internal and external corrosion free coating
- ✓ Consistent air quality to every outlet
- ✓ 10 years warranty on all products
- ✓ Leak free
- ✓ Minimal expansion; no sag or bow
- ✓ Total metal system
- ✓ Complies with Australian and European safety standards



## INFINITE ENERGY SAVING

- ✓ Extremely low pressure drop
- ✓ Leak free
- ✓ Reduced compressor loading and running cost
- ✓ Efficient condensate removal

## Zero Condensate Reducing Tee

One of the many technologically advanced features of the Infinity system is the zero condensate reducing tee.

This efficient internal system allows the fluid to reach its destination without any damaging condensation reaching equipment. Condensation stays within the ring main and can be drained off at the most convenient point.



The Zero Condensate Tee provides the advantage of automatically reducing the size of the ring main to a smaller drop leg diameter, making the need for extra fittings obsolete. Its internal geometric shape means that it can be used vertically or horizontally, and the internal barrel may be rotated by 360° for off shoot lines. Additionally, in many cases, the Zero Condensate Tee may replace a coupler when placed appropriately.

Designed specifically for compressed air distribution, the Infinity Zero Condensate Tee causes no laminar turbulence, ensuring consistent flow and pressure throughout the system.

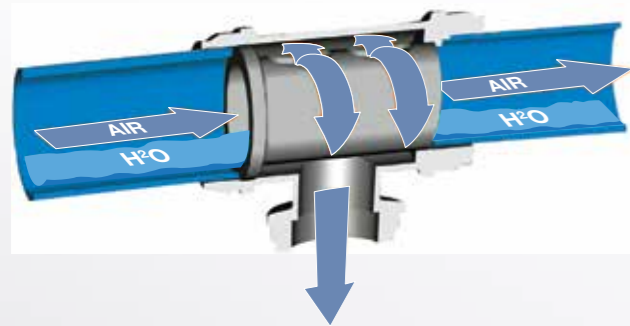

## Size for size, there is no comparison

When you compare the internal diameter of the Infinity aluminium pipe system with galvanised and plastic pipe of the same outside diameter, you'll find that there is one big advantage - air flow.

The thinner walls translates to a much larger internal diameter, providing on average a 23% increase in air flow.

In fact, aluminium bore size is so much larger that in most cases you can use the next size down of Infinity pipe and still achieve the same or better flow as plastic, which can have a considerable economic impact both in material costs as well as ongoing running costs.

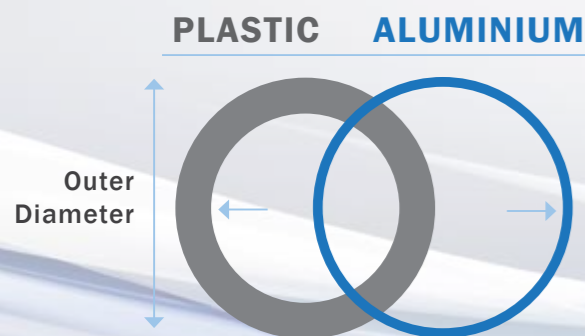

## Infinity Filtration Systems

**When air is compressed, the concentration of moisture and other contaminants increases.**

If allowed to remain in the system, this corrosive mixture has a detrimental effect on pneumatic equipment, causing unnecessary production downtime, product spoilage and reduced equipment life.

Infinity filters remove solid particles, moisture and odours from the air before it reaches it's destination. The range includes standard filters, regulators and lubricators for point of use, and larger Infinity industrial filters for main line applications.



## Infinity Hoses And Reels

**Infinity hose reels offer a quality economical solution, that will improve your safety record, increase efficiencies and productivity, and reduce costly downtime.**

The compact nature of Infinity hose reels allows for better hose management, resulting in a more organised and efficient work space, and the design and functionality means safer handling of hoses.

Infinity is pleased to offer a vast range of reels, hose, tubing and brackets, suitable to a wide variety of jobs and industries.

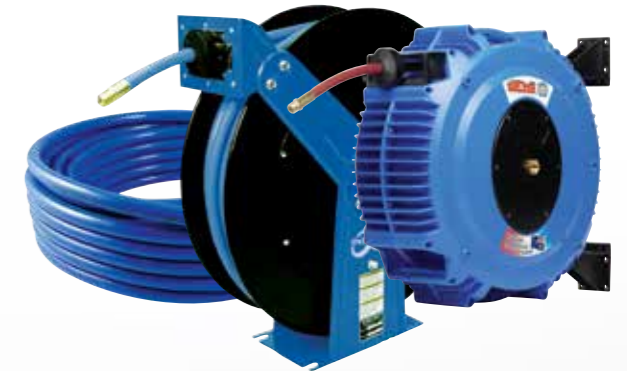

## Infinity Couplings

**Infinity offers a large selection of high quality couplings that are specifically designed for compressed air.**

The range includes carbon steel, aluminium, stainless steel and brass couplings, as well as complimentary adapters.



## Infinity Airline Accessories

**Infinity is pleased to offer a vast range of accessories, that will perfectly compliment your Infinity pipe system.**

The accessories range includes nickel plated brass push in fittings, adapters, fixings and a selection of extras.

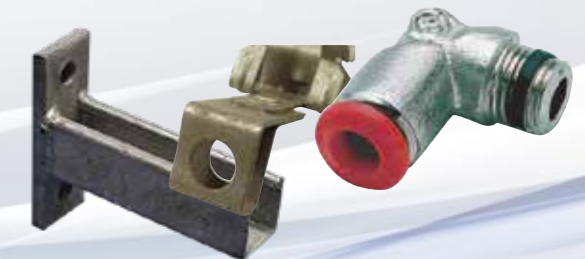

# Case Studies

## Cleanaway

### Recycling Plant, Australia

Infinity pipe was in the largest, most high-tech recycling facility in the southern hemisphere. Infinity Aluminium High Flow Pipe was installed throughout the plant to distribute consistent leak free compressed air to the new state of the art system.



## Coca Cola

### Soft drink manufacturer, Australia

As part of their factory renovation, Coca Cola required an airline system that could connect three 55kW variable speed compressors.

Infinity piping was utilised to ensure maximum capacity of these compressors and to optimise the flow of the airline system.



## Fonterra

### Dairy manufacturer, Australia

In a response to Fonterra's prevailing issue of pressure drop throughout their factory, a 70m long Infinity piping system was installed.

Connecting three compressors and two dryers with bypasses, the system was successful in optimising flow, reducing turbulence and maintaining pressure.



Supplied by:



**Head Office & Warehouse WA**  
274 Welshpool Road, Welshpool 6106 WA  
Phone: 08 9333 4920 Fax: 08 9333 4900  
Email: [info@infinitypipesystems.com.au](mailto:info@infinitypipesystems.com.au)  
[infinitypipesystems.com.au](http://infinitypipesystems.com.au)

**VIC Branch & Warehouse**  
1/17 Swift Way, Dandenong South 3175 VIC  
Phone: 0427 758 109

**QLD Branch & Warehouse**  
Phone: 0408 197 922